

Trunk Cable

The trunk cable is the backbone of the View Dynamic Controls system, providing both power and communications through a single cable and distributing it to the rest of the system.

Dimensions

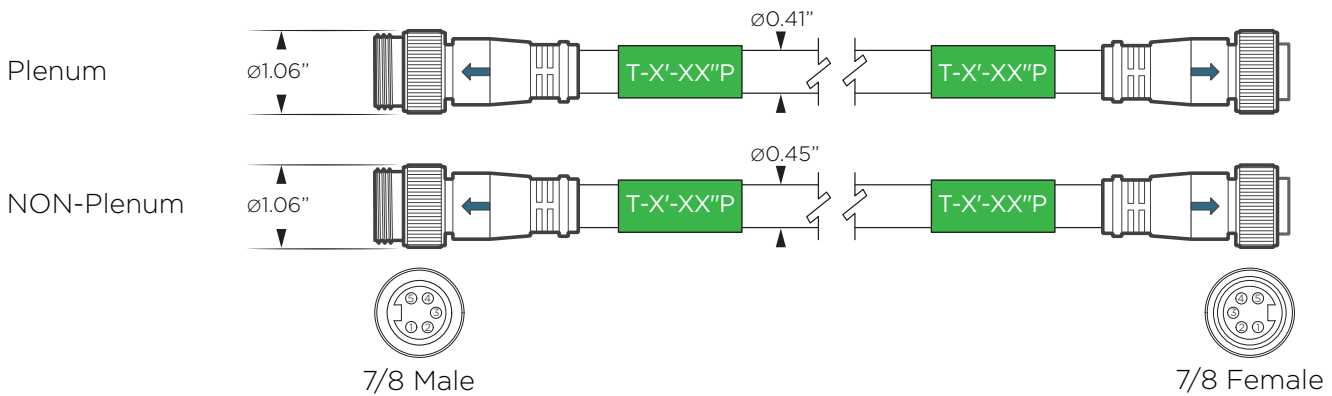

Application Example

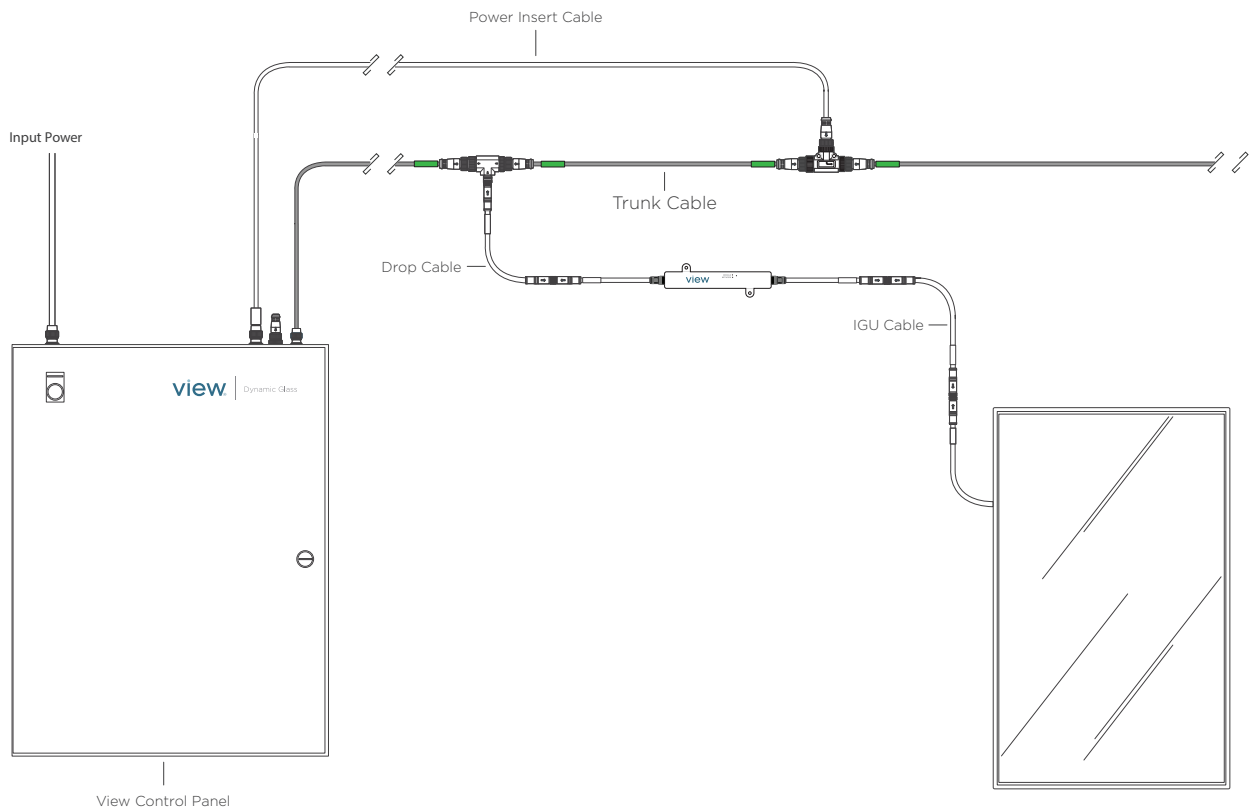

Bend Radius

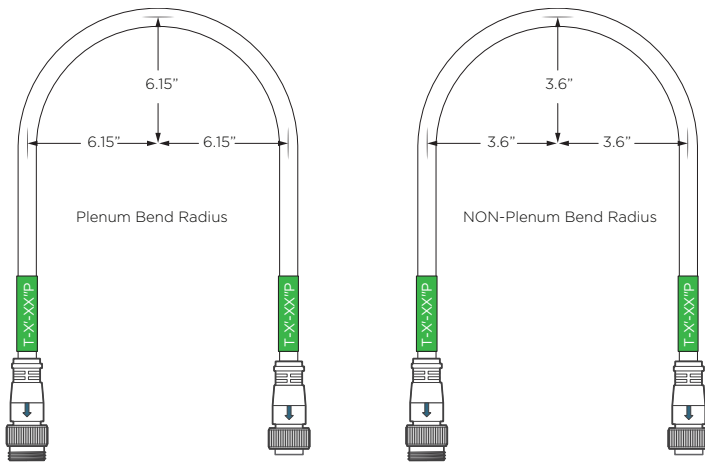

Wiring Diagram

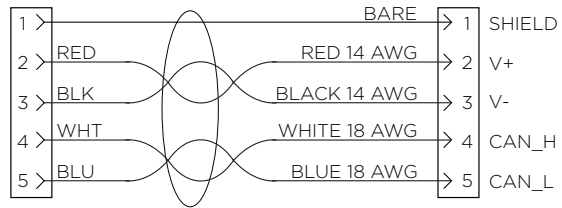

Interconnect Identification

Find number (Length) on colored wrap, both ends of cable.

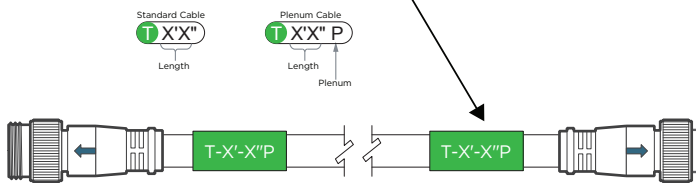

LENGTH CHART

XX	Length (ft)	Length (m)
01	1'0"	0.3
02	2'0"	0.6
03	3'3"	1.0
04	4'11"	1.5
05	6'6"	2.0
06	8'2"	2.5
07	9'10"	3.0
08	11'5"	3.5
00	13'1"	3.5
10	14'9"	4.0
11	16'4"	4.5
12	18'0"	5.0
13	19'8"	5.5
14	21'3"	6.0
15	22'11"	6.5
16	24'7"	7.0
17	26'2"	7.5
18	27'10"	8.0
19	29'6"	8.5
20	31'2"	9.0
21	32'9"	9.5
22	65'7"	10
23	98'5"	20
24	131'2"	30
25	164'0"	40

Specifications

Housing Material	Thermoplastic polyurethane (TPU)
Max Current	9A
Max Voltage	300V
Bend Radius	Plenum=6.15"; NON-Plenum=3.6"
Cable Rating	All cables are IP67 rated. Communications, Plenum cable (CMP) rated cables are available.
Warranty	All cables and components carry a warranty for a period of 5 years from date of delivery by View. Refer to standard warranty terms and conditions for more details.
Jacket	Plenum - PVC (Grade CMP); Non-Plenum - PVC
Rated Temperature (C°)	-20° to -75°C (Plenum) -20° to 80°C (Non-Plenum)
Used in conjunction with	Trunk Tee Connector, Trunk WYE Connector and Trunk Terminator
Routing locations	Above ceiling grids, within interstitials, within spandrel locations, within drywall spaces and within framing channels.
Cold Bend Testing (C°)	-20°C for four hours of exposure

Ordering Information

Part Number	Description (Replace XX desired part numbers corresponding to length (in feet/meter))
380-000057-XX	14 AWG Cables
380-000038-XX	14 AWG Cables Plenum

Requirements for Cold Weather Installation

If the cable has to be installed when the temperature is below 32°F, the following precautions should be taken to ensure that the jacket does not crack:

- Store the cable in a heated area with temperatures above 60°F for 24 hours before installation.
- Cables need to be handled with care and not dropped, kinked, or bent roughly.
- Pull cables slowly, use large sheaves and lubes suitable for cold temperatures.